

Women, Infants, and Children (WIC)  
Competent Professional Authority (CPA) Training Program

**WIC Anthropometrics Manual**



Nevada WIC Program  
400 W King Street, #300  
Carson City, NV 89703  
Phone: (775) 684-5942  
Fax: (775) 684-4246

Updated: February 2021

This page left intentionally blank.

## TABLE OF CONTENTS

<b>Introduction</b> .....	4
<b>Factors Affecting Growth</b> .....	6
<b>Procedures for Weighing and Measuring</b> .....	7
Measuring Length .....	7
Measuring Weight for Children Less Than 24 Months (2 Years) of Age .....	9
Measuring Standing Height .....	12
Measuring Standing Weight of Children 2 Years and Older and Adults .....	15
Common Measurement Errors .....	18
<b>Equipment Checklists</b> .....	19
No stature device attached .....	
<b>Forms</b> .....	20
<b>Calibration Recording Form</b> .....	21
<b>Plotting and Interpreting Growth Charts</b> .....	22
Why Use Growth Charts? .....	22
About WHO Growth Charts .....	22
About CDC Growth Charts .....	23
Interpreting CDC Growth Charts.....	24
Procedures for Plotting Growth Charts of Infants and Children.....	24
<b>Gestational (Prenatal) Weight Gain</b> .....	28
How to Read the Gestational Weight Gain Chart .....	29
Interpreting Anthropometric Measurements for Pregnant Women.....	32

## Introduction

---

**Anthropometry** refers to measurements of the body, such as length or height, weight, and head circumference.

**Length** refers to the recumbent measurement of:

- 1.) Infants and children less than two (2) years of age
- 2.) Children two years of age and above who cannot stand unassisted or measure <30 inches while lying down.

**Height** refers to the standing measurement of:

- 1.) Children at least two (2) years of age that measure > 30 inches
- 2.) All women (height is also referred to as stature).

### Purpose

In the WIC Program, anthropometric assessment involves measuring weight and length (or standing height) at specific times, depending on age and nutritional status. The measurements are compared with a reference population of healthy people by using growth charts for infants and children, and weight gain grids for pregnant women. This activity is part of the WIC nutrition and health assessment. Much can be learned about the nutritional status and general health of WIC applicants and participants when these measurements are used along with nutrition behaviors and blood values. These measurements are required to help determine WIC eligibility.

### Required Measurement Intervals

Height (or length) and weight must be obtained for all participants at each certification and mid-cert health check, at a minimum.

Note: For more information about required measurement intervals or accepting documentation for measurements see P&P Manual [CT: 07 – Nutrition Assessment and Risk Determination](#). If the values do not appear appropriate for the participant's age and / or situation, then the local agency will perform the measurement in the WIC clinic.

## Participant Category Considerations

If an infant is not available for weighing and measuring at the mid-certification health check, use the appropriate Inaccurate Reason in WISH if weight and length is taken verbally. If a child can't be accurately measured lying or standing due to a medical / physical disability, such as cerebral palsy, the measurement is to be obtained by the participant's health care provider. When doing a certification / recertification appointments, participants need to be physically present. Self-reporting of height and weight is not acceptable, except in the case of infant birth data.

Note: For more information about anthropometric data requirements for certifications and mid-certifications see P&P Manual [CT: 03 – Physical Presence](#).

As a WIC CPA you have an important role in helping pregnant women understand their pregnancy weight gain, and in helping parents and caregivers understand the growth patterns of their children.

## Factors Affecting Growth

Weight and length or standing height measurements of WIC applicants and participants are essential to:

1. Identify malnourished women, infants, and children.
2. Identify women, infants, and children at nutrition risk (in need of early counseling to prevent nutrition-related health problems).
3. Reassure parents that their children are growing normally; help reassure pregnant women that their weight gain is progressing normally.
4. Evaluate the effectiveness of nutrition services.

Growth and development are affected by several factors that interact with one another to determine an individual's growth pattern, including:

1. The quality and quantity of dietary intake, and environmental exposure to disease and illness.
2. Activity and exercise patterns, or heavy smoking and drug use during pregnancy.
3. Genetic factors (inherited family characteristics).
4. Hormones influence child growth patterns, and hormonal changes during pregnancy influence appetite and prenatal health. ("Morning sickness" is a common experience for many women early in pregnancy and is due, in part, to an increase in the secretion of a hormone called progesterone.)

## Procedures for Weighing and Measuring

---

In order to be useful as an indicator of health, measurements must be accurately performed, recorded, plotted on appropriate growth charts, and appropriately interpreted.

### Measuring Length

#### Equipment

To measure length of children from birth until 24 months and from 24-36 months in children who cannot stand unassisted or measure < 30 inches, you should use a tabletop measuring board to measure length of the child while lying down. The length board should be on a stable smooth flat surface and have a stable headboard with movable foot piece. Length board should be placed out of reach of dangerous objects, sink basins, or sharp edges. Length boards must be checked with standard length rods on at least a yearly basis. For satellite clinics, moveable stadiometers must be checked with standard rods after each time the equipment is moved.

#### ❖ *Definitions:*

- **Recumbent Length:** Length measured while lying down. Children from birth until 24 months and from 24 - 36 months in children who cannot stand unassisted or who measure < 30 inches while lying down must be measured using recumbent length.
- **Recumbent Length Board:** A measuring board with a fixed perpendicular headpiece and sliding foot-piece that forms a 90-degree angle with the measurement surface. Used for measuring recumbent length.

#### Technique

Children from birth-24 months and from 24 - 36 months who cannot stand unassisted or who measure < 30 inches must be measured lying down (recumbent length). Two people are needed to measure length. Parents or caregivers should participate in the length measurement to provide reassurance and security to the infant. Measurements should be read to the nearest 1/8<sup>th</sup> inch.

It is inappropriate to use improvised equipment for measuring length - such as measuring tapes or yardsticks attached to tabletops. Measuring between two pencil marks on an exam table does not provide an accurate measurement. Inappropriate equipment used for measuring tends to measure 'short.' A length measuring device attached to an infant scale is not accurate because the headpiece is not perpendicular or stationary and the foot-piece is not perpendicular to a stable table. A fixed head piece and a moveable foot piece which is set at a ninety-degree angle to the board are needed for accuracy as infants often attempt to draw their arms and legs together or push against the board.

To measure length, follow these steps:

1. Remove shoes, hats, and hair accessories and flatten big hair styles (if possible).
2. Put clean paper cloth on measuring board.
3. Lay child flat on his back in the center of the measuring board.
4. One person (could be the caregiver) cups her hands over the child's ears while holding the child's head firmly against the headboard (child's eyes should be facing the ceiling and the top of his / her head should be against the headboard). The infant's chin should not be tucked in against his chest or stretched too far back.
5. The second person brings the child's knees together and gently pushes down on them so that both legs are extended; one of their hands should rest on the child's knees or shins to prevent them from spreading apart or bending, while the other hand brings the movable footboard to rest firmly against the heels (toes should point upward and both feet need to be flat against the footboard). If only one of the infant's legs is extended during the measurement, the measurement may be unreliable and inaccurate.



Note: Attaining proper foot position may require multiple attempts if infants flex their feet or point their toes without relaxing. If initial attempts are unsuccessful, it is recommended to take a break and retry the measurement after infant becomes calm and relaxes. Caregivers may assist by soothing, and massaging infant's legs or feet. Another measurement can be performed after the infant relaxes. For situations when an infant will not relax or allow positioning for an accurate length, record the best attempt and document the reasons that an accurate measurement could not be obtained.



6. For all length boards: Read the length to the nearest 1/8<sup>th</sup> inch where the inside of the footboard touches the heel or where the measuring board indicates.

**For non-digital length boards only:**

While the infant remains in place, measure again to ensure accuracy of the reading. (only one measurement is needed for digital length boards)

If the first and second reading are different by more than ¼ inch, the infant should be re-measured a third time. Record the average of the two lengths that match most closely.

7. Record the length immediately in WISH on the Medical screen. Today's date will default as the date the measurement was performed.

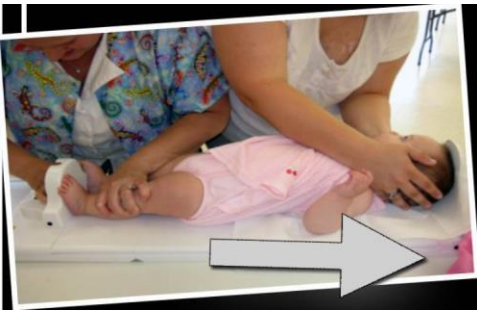

## Measuring Weight for Children Less Than 24 Months (2 Years) of Age

### Equipment

Infants may be measured with a beam balance scale with a tray and free-sliding weight (non-detachable) or an electronic scale. The scale should be marked in increments of one ounce (1 oz) and have a large enough tray to adequately support an infant or young child who weighs up to 40 pounds (20 kilograms). If a child 24-36 months cannot stand unassisted, they may also be weighed on the infant scale. Children older than 36 months should be weighed standing on a scale. The scale is to be calibrated yearly and the calibration is to be documented.

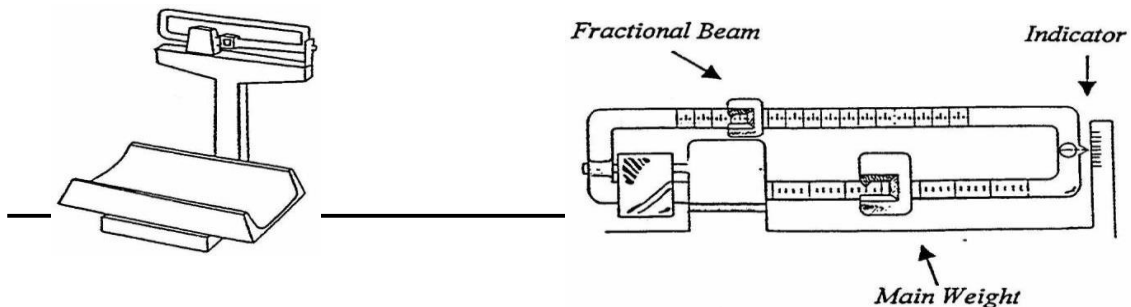

## Technique

The scale should rest on a firm, flat, stable table and care must be taken to protect the child from accidents throughout the procedure.

1. Put clean paper cloth on scale.
2. Balance the scales at zero (with paper sheet on tray) by placing the main and fractional sliding beam weights directly over their zero positions. If using an electronic scale, zero the scale with the paper sheet on the tray. Make sure the scale is set to measure in pounds and not kilograms.
3. Have the caregiver remove the infant or child's outer clothing including shoes, hats, mittens, jackets, sweaters, sweatshirts, and jumpsuits, etc. It is recommended to undress the child to only a dry diaper or single layer of light clothing such as a t-shirt or onesie for accurate weighing. (A wet diaper can weigh as much as 2½ pounds). "Light clothing" may be considered only those garments necessary for participant modesty and comfort.

At a minimum, take off shoes or boots, all outerwear, and heavier clothing, such as jackets, sweaters, or sweatshirts. Also remove items such as toys, packages, and purses. (Note: Document the clothing worn by participants dressed in heavy fabrics or insulated garments as the only layer of clothing which cannot be removed.)

4. Place the young child / infant lying in the center of the scale. Older children up to 24 months do better if placed sitting in the center of the scale. Have the caregiver help by keeping the infant stable and protected from harm (falling, etc.), but they should not touch or hold the infant while being weighed.
5. To take the reading, move the large counterbalance on the main beam away from the zero position until the indicator drops, showing that a little too much weight has been added. Then back off to the nearest stop until the indicator rises, showing that a little too much weight has been removed. Repeat the above procedure with the fractional beam until the indicator rests in the exact center.
6. **For all scales:** Read the weight to the nearest one ounce (1 oz).

### **For balance beam scales only:**

While the infant remains in place, repeat the measurement. (Only a single measurement is required for digital scales.)

If the first and second measurements are different by more than ¼ pound (4 oz), the infant should be reweighed a third time. Record the average of the two weights that match most closely.

7. Record the weight immediately in WISH on the Medical screen. Today's date will default as the date the measurement was performed.

**NOTE: Document any situations when measurements are not taken by WIC staff or measurement accuracy may be affected. A statement documenting that the outside documentation was provided from a provider and any additional important information (e.g., dirty diaper, weighed with shoes on, etc.) listed on the documentation in WISH.**

\*Measurement Date 02/19/2021 At Age 2 y 3 m

Birth Measurement  Unknown

Weight

Fraction  Decimal  Metric

lbs Inaccurate Reason

Length/Height

Fraction  Decimal  Metric

in Inaccurate Reason

Birth

Fr

Weight: 5 15 lbs/oz

Excess Clothing  
Noncompliant  
Wet/Dirty/Diaper  
Refused  
Special Needs  
Referral Data  
COVID 19  
Other

- Return the weights to the zero position at the left-hand side of the scale to help maintain scale accuracy. Remove the disposable paper cloth.

### Difficulty Taking Measurements

Sometimes a child may be unmanageable. Make every effort to obtain as accurate a measurement as possible. Inappropriate counseling and education may result from inaccurate measurements. A parent may worry unnecessarily about poor growth or overweight in their child when the child is actually growing appropriately, or a true growth problem may not be identified with incorrect measurements.

We must have anthropometric data to determine WIC eligibility. Therefore, if a child is hysterical, screaming, kicking, and cannot be comforted, he can be weighed in his caregiver's arms. The caregiver is weighed alone, and his / her weight is recorded. The caregiver is then weighed with the child and this second weight is recorded. The caregiver's weight is then subtracted from the second reading (caregiver and child together). Record "weight obtained in caregiver's arms" in Anthropometrics panel in WISH.

### Reading Measurements

When taking the weight of a child, proper technique is very important. Equally critical, is knowing how to properly read the measurement. This can be difficult, as each increment on the balance beam infant scale can be quite small. You may also not be familiar with measuring ounces (oz), which really are just fractions of a pound (lb).

The first thing you need to know is that one (1) pound equals 16 ounces. Therefore, one half (1/2) of a pound equals eight (8) ounces.

### Rounding Measurements

Most weight measurements will not be exactly on a one-ounce (1 oz) increment. Therefore, you will need to round the reading. Round to the closest ounce as follows:

If the measurement lies closer to one (1) ounce interval than to another, round to the nearest ounce. For example, if your measurement lies closer to 10 ounces than to 11 ounces, then you should round down to 10 ounces; however, if it is closer to 11 ounces, you should round up to 11 ounces.

## Measuring Standing Height

### Equipment

To measure standing height of children two (2) years of age and older and adults, you should use a stadiometer with a moveable headboard at least six (6) inches wide. However, if a child is 24-36 months and measures <30 inches, they should still be measured lying down (recumbent length). There should not be carpet underneath the measuring board. It should be mounted and, therefore, immovable. The equipment must be installed according to manufacturer's instructions and routinely monitored to verify compliance. Stadiometers must be checked with standard length rods on at least a yearly basis. In satellite clinics, this equipment may be portable; ensure that the base is not too small, thereby making it unstable and not perpendicular to the floor. Moveable stadiometers must be checked with standard rods after each time the equipment is moved.

Note: The moveable measuring rod on platform scales should **NOT** be used for measuring height. It is not accurate because it is too narrow, unsteady, and can be too easily bent. If possible, the measuring rod should be removed; children often play with the rod and removing it may prevent injury.

A measuring rule made of flat, metal material can be attached to a wall (or any vertical, flat surface). The rule should be marked in 1/8<sup>th</sup> inch increments. A headboard or right-angle block must be used with this technique. The headboard should be wide enough (at least six (6) inches) to measure only at the participant's crown (i.e. top of head) and create a right angle to the measurement surface.

Caution: If mounted on sheet rock, check that it's not working its way down the wall with use.

Staff may need to stand on a sturdy step stool to accurately read the height of adults.

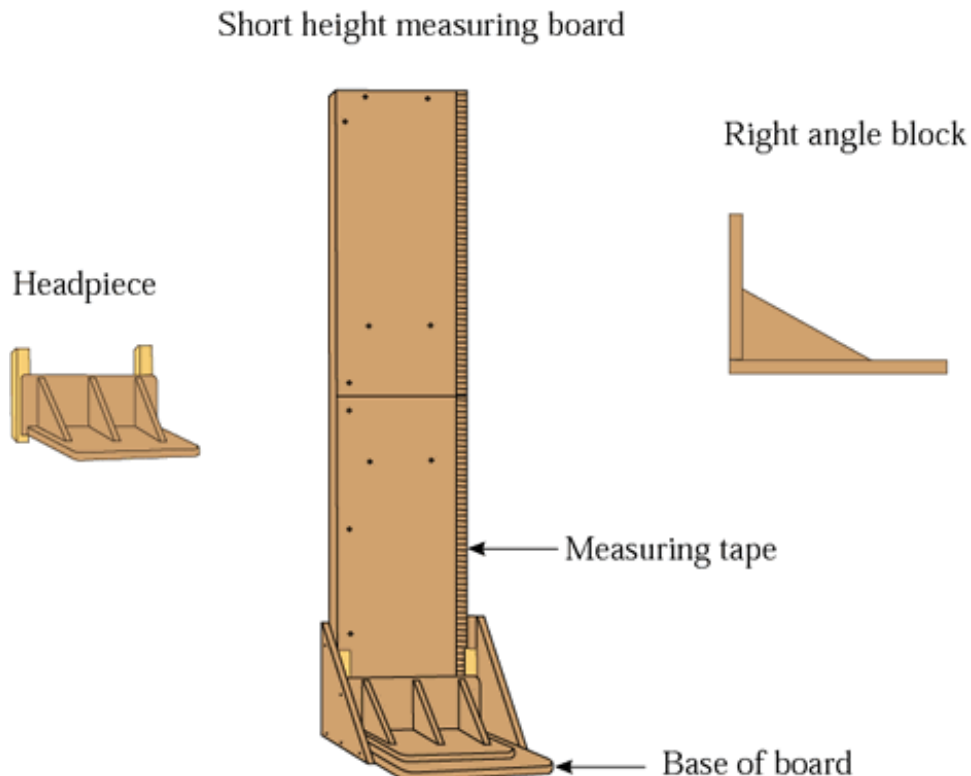

## Technique

It is helpful to have two people taking the stature of a child, one to take the measurement and one to hold the lower body in position. This will not be necessary for adults, but be sure to check positioning before taking the measurement.

If a child or adult has an elaborate hairstyle that cannot be removed, do the best you can. It is recommended to use a flat small implement or a pencil and carefully slide through the base of the hairstyle as close to the crown of the head as possible until it makes contact with the measuring surface. Read where the pencil point hits the measuring surface. Read where the pencil point hits the measuring surface.

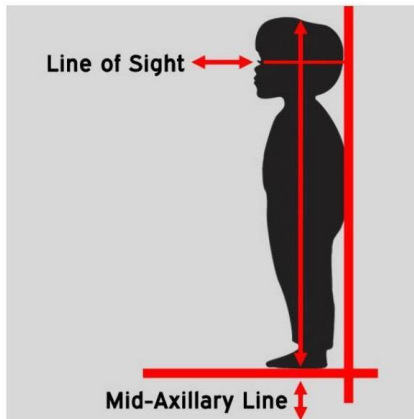

1. Remove shoes, hats, and hair trims and flatten large hairstyles when possible. Place clean paper where child or adult stands.
2. The child or adult should stand tall and straight, with shoulders level, hands at sides, knees or thighs together (whichever touch first), and feet flat on floor or foot piece. The position of the body should follow the **mid-axillary** line where the ear lines up with the middle of the shoulder and the middle of the arch in the foot (see figure on left).
3. The person taking the measurement should be directly to the side of the child or adult. If assistance is needed to help the participant attain proper head position, he / she should place his / her hand firmly on the participant's chin.
4. Locate the **Frankfurt plane** by looking at the middle of the participant's ear (the hole) and line it up with the bone of the eye socket (just below the eye). This may cause the participant to be looking slightly downward. It will allow you to appropriately measure at the crown of the head.
5. Lower the headboard (or right-angle block) until it firmly touches the crown of the head and creates a right angle with the measurement surface. Ensure that the lower body stays in position by firmly pressing hands on the knees and thighs.



- For all stadiometers: Read the stature to the nearest 1/8<sup>th</sup> inch where the bottom of the headboard touches the measuring tape.

For non-digital stadiometers:

While the child or adult remains in position, measure again. (only a single measurement needed for digital stadiometers)

If the difference between the two measurements is more than ¼ inch, they should be measured a third time. Record the average of the two heights that match most closely.

- Record the height immediately in HANDS on the Medical screen. Today's date will default as the date the measurement was performed.

Note: It is helpful to have two people taking the stature of a child, one to take the measurement and one to hold the lower body in position. This will not be necessary for adults, but be sure to check positioning before taking the measurement.

If a child or adult has an elaborate hairstyle that cannot be removed, do the best you can. It is recommended to use a flat small implement or a pencil and carefully slide through the base of the hairstyle as close to the crown of the head as possible until it makes contact with the measuring surface. Read where the pencil point hits the measuring surface.

### Reading Measurements

Reading the measurement for a standing height is very similar to how you learned to read the recumbent (lying down) length for children up to 24 months. The tape may look a bit different, but the principles are the same. Remember that you are still reading to the nearest 1/8<sup>th</sup> inch.

Now that you are taking a standing height, it is important that your eyes are at the same level as where you are reading the measurement. Therefore, you may have to bend down when measuring a child or use a step stool when measuring adults.

### Rounding the Measurement

If you measure the length to be between the 1/8<sup>th</sup> and 2/8<sup>th</sup> line, try to determine which line is closer and round to that number. If it appears to be exactly in the middle, then round down to the lower 1/8<sup>th</sup> of an inch. For example, if it is between 5/8<sup>th</sup>s and 6/8<sup>th</sup>s, unless it seems closer to the 6/8<sup>th</sup>s, round down to the 5/8<sup>th</sup>s mark.

**NOTE:** If measurements may have any inaccuracies or from outside/verbal source, make sure to record in reason in WISH.

The screenshot shows the HANDS software interface for recording measurements. It features two main sections: 'Weight' and 'Length/Height'. Each section has radio buttons for 'Fraction', 'Decimal', and 'Metric'. The 'Weight' section is set to 'Fraction' and 'lbs', with an 'Inaccurate Reason' dropdown menu. The 'Length/Height' section is also set to 'Fraction' and 'in', with an 'Inaccurate Reason' dropdown menu. A dropdown menu is currently open, showing options: 'Referral Data', 'Noncompliant', 'COVID 19', and 'Other'. The 'Current' status is indicated in the top right corner.

## Measuring Standing Weight of Children 2 Years and Older and Adults

### Equipment

A beam balance scale with a platform and free-sliding weights (non-detachable) is the recommended form of equipment. The scale should be marked in increments of four ounces (4 oz) or 100 grams (g) or  $\frac{1}{4}$  pound. The scale should have a large enough platform to support the person being weighed. Electronic scales are also acceptable if this is what is available in your clinic. The scale is to be calibrated yearly and the calibration is to be documented.

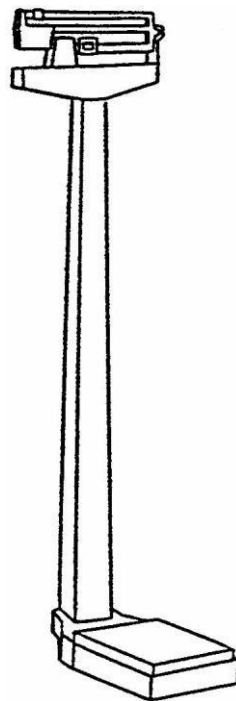

Spring balance scales (such as bathroom scales) are not recommended. The spring counterbalance loses accuracy over time and many scales are not capable of reading more accurately than  $\frac{1}{2}$  pound. Most bathroom scales are difficult to read since measurements are read at floor level.

## Technique

The scale should rest on a firm, flat, non-carpeted surface. For children and adults, there is a need to respect privacy. This includes where the measurements are taken, clothing removal, describing the measuring process, and interpreting the numbers.

1. Place clean paper on foot area. Confirm that the sliding weights on horizontal beam are at the zero position and that the scale is in balance.
2. Have adult participant (or caregiver of child participant) remove outer clothing including shoes, hats, mittens, jackets, sweaters, sweatshirts, and jumpsuits, etc. It is recommended to undress the child to only a dry diaper or single layer of light clothing such as a t-shirt or onesie for accurate weighing. (A wet diaper can weigh as much as 2½ pounds). “Light clothing” may be considered only those garments necessary for participant modesty and comfort.

At a minimum, take off shoes or boots, all outerwear, and heavier clothing, such as jackets, sweaters, or sweatshirts. Also remove items such as toys, packages, and purses. (Note: When measurements must be taken for participants dressed in heavy fabrics or insulated garments as the only layer of clothing, document the circumstances.)

3. Have the participant stand in the center of the platform with body upright and arms hanging naturally.
4. To take the reading, move the large counterbalance on the main beam away from the zero position until the indicator drops, showing that a little too much weight has been removed. Repeat the above procedure with the fractional beam until the indicator rests in the exact center.
5. For all scales: Read the weight to the nearest one ounce (1 oz).

For digital scales only:

Record the weight immediately in WISH on the Anthropometrics panel. Today’s date will default as the date the measurement was performed.

For balance-beam scales:

While the child or adult remains in position, repeat the measurement. (Only a single measurement is needed for digital scales.)

If the difference in the two measurements is greater than ¼ pound (4 oz), they should be measured a third time. Record the average of the two weights that match most closely. Today’s date will default as the date the measurement was performed.

6. Return the weights to the zero position at the left-hand





side of the scale.

7. Record the weight immediately in WISH on the Anthropometrics panel. Today's date will default as the date the measurement was performed.

### Reading the Measurement

When taking the weight of a child over age two (2) or an adult, proper technique is important. Equally critical is to know how to properly read the measurement. As with the infant scale, the scale should read in increments of one (1) ounce.

Remember, 16 ounces equals one (1) pound. So eight (8) ounces equals one half ( $\frac{1}{2}$ ) pound and four (4) ounces equals  $\frac{1}{4}$  pound.

Converting pounds to ounces

Pounds	Ounces
1 pound	16 ounces
$\frac{1}{2}$ pound	8 ounces
$\frac{1}{4}$ pound	4 ounces

### Rounding measurements

The same rules apply as for all other measurements; round to the nearest ounce (oz). Round down if the measurement lies exactly in the middle of two-ounce marks or closer to the lower ounce mark; otherwise, round up to the next ounce.

## Common Measurement Errors

Accuracy of data collection is dependent upon following procedures and techniques for measuring height or length and weight carefully. It is also necessary to record, plot, and interpret those measurements properly. The goal is to minimize the number of errors that can occur, since many clinical decisions and interventions are based on physical measurements. The list below shows many of the errors to avoid.

### All measurements:

1. Improper equipment (i.e. bathroom scales, stretchable tapes not properly attached to the wall.
2. Poorly maintained equipment (i.e. worn, loose, or broken sliding headboards or footboards on recumbent measuring boards)
3. Inaccurate reading due to restless child
4. Scale not adjusted to zero before weighing
5. Reading measurement incorrectly
6. Recording errors

### Length:

1. Incorrect equipment used for age of the child
2. Shoes and hats not removed
3. Head not held straight above the body
4. Head not firmly against fixed end of board (head bent to the side)
5. Child not straight along board
6. Body arched
7. Knees bent
8. Feet not parallel to movable board
9. Board not firmly against heels
10. Board not on flat surface

### Height:

1. Incorrect equipment used for age of the child
2. Shoes and hats not removed
3. Feet not straight or flat on floor
4. Knees bent
5. Body arched and improperly aligned
6. Frankfurt plane not achieved
7. Shoulders not straight
8. Head not held straight above the body
9. Headboard not firmly on crown of head

### Weight:

1. Outer, heavy clothing not removed
2. Child measured with wet diaper
3. Scale not adjusted to zero before weighing
4. Child moving or fidgeting

## **Equipment Checklists**

---

All equipment must be used for the purpose for which it is designed.

### Child and Adult Stadiometer Checklist

**Stadiometers must be stable, calibrated, and dedicated to the purpose. This requires:**

- ✓ A vertical board with an attached metric rule
- ✓ An easily moveable horizontal headboard, at least six (6) inches wide, that can be brought into contact with the crown of the head
- ✓ A wide and stable platform or firm uncarpeted floor as the base
- ✓ Firmly mounted on a stable wall
- ✓ Easily read, stable tape or digital readout in 1/8<sup>th</sup> inch increments

### Child and Adult Scale Checklist

**A scale for weighing children and adults should be stable, ensure privacy, and:**

- ✓ High quality beam balance or electronic digital
- ✓ Weight in four ounces (4 oz) or 100 grams (g) or 1/4 lb increments
- ✓ Weight can be 'locked' in (notches on beam balance scale)
- ✓ Weight is read at 'eye level' of measurer
- ✓ Stable weighing platform
- ✓ Can be easily 'zeroed' and checked
- ✓ Can be calibrated
- ✓ No stature device attached
- ✓ Wheels must be locked and not roll when bumped or stood on. The scale must be calibrated every time it is moved to another location.

### Infant Scale Checklist

**A scale for weighing infants should have a large enough tray to support the infant and weigh to 20 kg or 40 lb.**

- ✓ High quality beam balance or electronic digital
- ✓ Weighs to 20 kg or 40 lb
- ✓ Weighs in one ounce (1 oz) increments
- ✓ Tray large enough to support the infant
- ✓ Can be easily 'zeroed' and checked
- ✓ Weight can be 'locked' in
- ✓ Can be read at 'eye level' of measurer (acceptable portable scale during home visits may not have this feature).
- ✓ Can be calibrated
- ✓ Motion detector and stabilizer
- ✓ No length device attached

## Infant Lengthboard Checklist

**Lengthboards for infants must be sturdy, easily cleaned, and specific to the purpose and have:**

- ✓ A firm, inflexible, flat horizontal surface with a measuring tape in 1/8<sup>th</sup> inch increments
- ✓ Tape is stable and easily read
- ✓ An immovable headboard at a right angle to the tape
- ✓ A smoothly moveable footboard, perpendicular to the tape

There are many sources of high quality, reliable measurement equipment. These sources include several mail order and web-based companies. The information provided below is intended only as a guide and is not an endorsement of specific products, services, or manufacturers.

Some distributors of scales are: [Tanita](#), [Detecto](#), [Seca](#). Some distributors of lengthboards and stadiometers are: [Perspective Enterprises](#), [Measurement Concepts](#). Calibration weights are available from [Perspective Enterprises](#).

Note: Portable scales and measuring boards are acceptable if they meet WIC / HHS standards as stated above.

## **Forms**

---

### **Equipment Maintenance**

Maintenance is a regular, daily event.

- 1) Scales must be checked and 'zeroed' before each daily clinic and between each use. When nothing is being weighed, the scale should register 'zero.'
- 2) Supervisor is to observe staff on a regular basis to ensure that the scales are 'zeroed' every time.
- 3) Local Agency is required to train all staff on how to 'zero' a scale and ensure continuous training.



## Plotting and Interpreting Growth Charts

---

### Why Use Growth Charts?

Anthropometric growth charts show the progress of a child's growth in length or height and weight over time. They are an additional resource to help assess nutritional status.

A growth chart is a permanent part of a child's health record so that the health care provider, along with the parents or caregivers, can follow a child's growth over time.

**CDC recommends that health care providers use the WHO growth charts to monitor growth for infants and children under 2 years of age.** The WHO standards reflect growth patterns among children who were predominantly breastfed for at least 4 months and still breastfeeding at 12 months. The WHO growth charts are standards; they identify how children should grow when provided optimal conditions.

**CDC recommends to use the CDC growth charts to monitor growth for children age 2 years and older.** The CDC growth charts represent patterns of growth developed from studies of normal, healthy children.

### About WHO Growth Charts

In 1993, WHO established a working group on infant growth to conduct a comprehensive review of the uses and interpretation of the 1977 National Center for Health Statistics (NCHS)/WHO growth reference, which had been recommended for international use since the late 1970s.

The WHO Child Growth Standards were developed using data collected in the WHO Multicentre Growth Reference Study. The WHO Multicentre Growth Reference Study (MGRS) was undertaken between 1997 and 2003 to generate new growth curves for assessing the growth and development of infants and young children around the world.

The MGRS collected primary growth data and related information from approximately 8500 children from widely different ethnic backgrounds and cultural settings (Brazil, Ghana, India, Norway, Oman and the USA).

The new growth curves are expected to provide a single international standard that represents the best description of physiological growth for all children from birth to five years of age and to establish the breastfed infant as the normative model for growth and development.

### WHO Percentile Cutoff Values Differ from Traditional CDC Cutoff Values

The cutoff values for the 2nd and 98th percentiles used in the WHO growth standard charts are different from those used in the CDC growth references chart. CDC uses the 5th and 95th percentiles. Different methods are used to create the WHO and CDC charts.

## **WHO Growth Standards Represent Optimal Growth**

The WHO growth standard charts are intended to reflect normal child growth under optimal environmental conditions.

Although many children in the United States do not experience the optimal environmental, behavioral, or health conditions specified in the WHO Multicenter Growth Reference Study, the WHO growth standard charts are intended for use with children younger than age 24 months because they represent optimal growth.

[http://www.cdc.gov/nccdphp/dnpao/growthcharts/who/using/assessing\\_growth.htm](http://www.cdc.gov/nccdphp/dnpao/growthcharts/who/using/assessing_growth.htm)

## **About CDC Growth Charts**

The CDC growth charts consist of a series of percentile curves that illustrate the distribution of selected body measurements in U.S. children. Pediatric growth charts have been used by pediatricians, nurses, and parents to track the growth of infants, children, and adolescents in the United States since 1977. The 1977 growth charts were developed by the National Center for Health Statistics (NCHS) as a clinical tool for health professionals to determine if the growth of a child is adequate. The World Health Organization (WHO) also adopted the 1977 charts for international use.

When the 1977 NCHS growth charts were first developed, NCHS recommended that they be revised periodically as necessary. With more recent and comprehensive national data now available, along with improved statistical procedures, the 1977 growth charts were revised and updated to make them a more valuable clinical tool for health professionals. The 2000 CDC growth charts represent the revised version of the 1977 NCHS growth charts. Most of the data used to construct these charts come from the National Health and Nutrition Examination Survey (NHANES), which has periodically collected height, weight, and other health information on the American population since the early 1960's.

Growth charts are not intended to be used as a sole diagnostic instrument. Instead, growth charts are tools that contribute to forming an overall clinical impression for the child being measured. The revised growth charts provide an improved tool for evaluating the growth of children in clinical and research settings.

### **The 2000 CDC Growth Charts and the New Body Mass Index-For-Age (BMI-for-age) Charts**

The CDC growth charts used in WIC consist of 10 charts (five (5) for boys and five (5) for girls). The CDC charts currently used in WIC are:

- 1. 2-20 BMI/age for boys and girls**
- 2. 2-20 Weight/age for boys and girls**
- 3. 2-20 Height/age for boys and girls**

4. **24-36 months wt/length for boys and girls who are not able to be measured standing**
5. **24-36 months length/age for boys and girls who are not able to be measured standing**

BMI ( $\text{wt}/\text{ht}^2$ ) is calculated from weight and height measurements and is used to judge whether an individual's weight is appropriate for their height. BMI is the most commonly used approach to screen adults for overweight or obesity and is also the recommended measure to be used with children.

### **Interpreting Growth Charts**

Growth charts show you how each child is growing over time. The CDC charts in WISH have lines with the numbers 5, 10, 25, 50, 75, 85, 90, and 95. The WHO charts in WISH have lines with the numbers 2, 10, 25, 50, 75, 90, 95, 98. These curves and percentiles serve as reference for comparison. The height and weight of a child will be plotted and then compared to these percentiles.

A growth chart is a valuable tool for assessing a child's growth over time and can be used as an educational tool for parents and caregivers. Several measurements plotted at different ages give information on how the child's growth is progressing. Most children grow along the same percentile curve, although "spurts" are normal.

### **Procedures for Plotting Growth Charts of Infants and Children**

When you enter height or length and weight information into WISH, it will automatically plot those measurements on the appropriate growth chart for you.

Note: If a child 24-36 months is measured recumbent, make sure that you select the appropriate 'Inaccurate Reason' if needed. (e.g. Special Needs). WISH will also calculate the adjusted age of a premature infant and plot the graph with both actual and adjusted age plots.



## Interpret the plotted measurements

### WHO Growth Charts

- Determine the percentile rank.
- Determine if the percentile rank indicates a possible nutritional risk.
- Compare today's percentile rank with the rank from previous visits to identify any major shifts in the child's growth pattern and the need for further assessment. For example, a child whose weight has been tracking on the 75<sup>th</sup> percentile curve and now is at the 25<sup>th</sup> percentile curve may still fall in a "normal" range, but this is not a normal growth pattern for that particular child and should be investigated further.
- Measurements falling between the 2<sup>nd</sup> and 98<sup>th</sup> percentile represent average growth for optimally fed infants and children under age two. This average growth range is often referred to as "normal" growth, even though individuals vary greatly in what is normal growth for them. The following terms regarding nutrition implication may be used to discuss growth patterns falling outside of that range.

Anthropometric Indicator	Percentile Rank	Risk Assigned
Weight-for-Length	<b>At or above 98<sup>th</sup></b>	<b>115</b>
Weight-for-Length	<b>Less than 98<sup>th</sup> and above 5<sup>th</sup></b>	<b>None</b>
Weight-for-Length	<b>Less than or equal to 5<sup>th</sup> and above 2<sup>nd</sup></b>	<b>103.A</b>
Weight-for-Length	<b>At or below 2<sup>nd</sup></b>	<b>103.B</b>

### CDC Growth Charts

The curved lines on the growth chart show selected percentiles indicating the rank of the measure in a group of 100. For example, when a dot is on the 95<sup>th</sup> percentile line for BMI-for-age, it means that only 5 of 100 children (5%) of the same age and sex have a higher BMI-for-age. Interpret the plotted measurements based on the percentile ranking and the corresponding nutrition indicator shown in the table below. If the percentile rank indicates a nutrition-related health concern, additional monitoring and assessment is recommended.

- Determine the percentile rank.

- Determine if the percentile rank indicates a possible nutritional risk.
- Compare today’s percentile rank with the rank from previous visits to identify any major shifts in the child’s growth pattern and the need for further assessment. For example, a child whose weight has been tracking on the 75<sup>th</sup> percentile curve and now is at the 25<sup>th</sup> percentile curve may still fall in a “normal” range, but this is not a normal growth pattern for that particular child and should be investigated further.
- Measurements falling between the 10<sup>th</sup> and 90<sup>th</sup> percentile represent average growth. This average growth range is often referred to as “normal” growth, even though individuals vary greatly in what is normal growth for them. The following terms regarding nutrition implication may be used to discuss growth patterns falling outside of that range.

Anthropometric Indicator	Percentile Rank	Risk Assigned
BMI-for-Age	<b>At or above 95<sup>th</sup></b>	<b>113</b>
BMI-for-Age	<b>Between 85<sup>th</sup> and 95<sup>th</sup></b>	<b>114</b>
BMI-for-Age	<b>At or below 10<sup>th</sup> but greater than 5<sup>th</sup></b>	<b>103.B</b>
BMI-for-Age	<b>At or below 5<sup>th</sup></b>	<b>103.A</b>

Once you have interpreted the readings on the growth chart, you will calculate risk factors and discuss the findings with parents / caregivers. Please be sensitive to the feelings of the child and parents / caregivers and do not use “value” or judgmental terms.

For purposes of certification, apply the following values for definition of High Risk:

### High Risk Assignment: WHO Growth Charts

High Risk Referrals related to Anthropometry for children under two years include the following criteria:

- **weight-for-length** at or above 98<sup>th</sup> percentile
- **weight-for-length** less than or equal to the 2<sup>nd</sup> percentile
- **Failure to Thrive** – diagnosed by a physician as self-reported by applicant / participant / caregiver or as reported or documented by a physician or someone working under the physician's orders.
- **Low Birth Weight** – weighing less than or equal to 5 pounds 8 ounces ( $\leq 2500\text{g}$ ) for infants and children less 24 months of age.

### High Risk Assignment: CDC Growth Charts

High Risk Referrals for children at least two years old and adults include the following criteria:

- **BMI** at or above 95<sup>th</sup> percentile
- **BMI** less than or equal to the 5<sup>th</sup> percentile weight-for-length or BMI-for-age at certification.
- **Failure to Thrive** – diagnosed by a physician as self-reported by applicant / participant / caregiver or as reported or documented by a physician or someone working under the physician's orders.

If a child has a special medical condition, such as Downs Syndrome, or if their growth does not plot on a standard growth chart, they may need to be charted on a specialized growth chart. These children should be referred to the nutritionist.

## Gestational (Prenatal) Weight Gain

---

The prenatal weight gain chart in WISH is a graph comparing a pregnant woman's weight gain to the recommended pregnancy weight gain range. The recommended weight gain range depends on the woman's pre-pregnancy weight.

After recording measurements in WISH, the correct graph according to pre-pregnancy BMI will be automatically selected by the system. The graph will display two lines representing the lower and upper range for recommended weight gain throughout pregnancy for the participant (based on pre-pregnancy BMI category). WISH will plot the participant's present weight gain according to the number of weeks gestation. Subsequent measurements will be plotted each time the participant is weighed during the pregnancy to compare how the participant's weight gain tracks compared to the recommended range of weight gain.

Every woman's weight gain is not going to fall within the lines. A woman increases her chances of a healthy pregnancy by using these weight gain recommendations as a target during her pregnancy.

The charts are useful for providing a picture of the pregnancy weight gain. They are an additional resource in your assessment of prenatal nutrition status. The pattern of weight gain is as important as the total weight gain. **A slightly lower or higher rate of weight gain than that recommended is not cause for alarm, as long as there is a progressive increase that is close to the recommended rate.**

### **Target Weight Gain by Pre-pregnancy Weight**

Underweight Woman	28-40 pounds
Normal Weight Woman	25-35 pounds
Overweight Woman	15-25 pounds
Obese Woman	11-20 pounds

### **Women pregnant With Twins**

Under Weight	50-62 pounds
Normal Weight	37-54 pounds
Overweight	31-50 pounds
Obese	25-42 pounds

## How to Read the Gestational Weight Gain Chart

### Vertical Lines

The Gestational Weight Gain Chart has numbers on the bottom of the graph. Each vertical line, running top to bottom, represents 2 weeks of pregnancy. Note: Trimesters are periods of three months or about 13 weeks. The first trimester includes weeks 1-14, the second trimester includes weeks 14-27, and the third trimester includes weeks 27-40. The trimesters are also marked by bold vertical lines.

### Horizontal Lines

The horizontal lines on the Gestational Weight Gain Chart represent pounds of weight gain or weight loss compared to pre-pregnancy weight. The zero line is the 'starting' weight or pre-pregnancy weight. The figures above zero represent weight gain and the figures below zero represent weight loss.

Each chart has a set of sloping lines that go up towards the right-hand side of the chart. The final target weight gain range is found where these two sloping lines cross week 40 of pregnancy.

Weight gain above the top sloping line may show the woman has gained too much weight in the pregnancy. Weight gain below the bottom sloping line may indicate she has not gained enough weight.

The slope of the lines and the areas between them are different depending on the pre-pregnancy BMI category of the woman

*Remember that the recommended weight gain varies, depending on the woman's pre-pregnancy weight and BMI.*

### Pre-pregnancy Weight Status

Assessing pre-pregnancy weight involves obtaining the woman's height and pre-pregnancy weight.

If the woman does not know her pre-pregnancy weight, the following questions may assist you in determining an approximate weight.

"Did the doctor or clinic staff weigh you when you found out you were pregnant? What was that weight?"

"Do you think you gained any weight between the time you became pregnant and when you first were weighed? How much do you think that was?"

If a woman does not remember her pre-pregnancy weight and there are no previous records, you can still evaluate her future weight gain. This will be discussed later.

## Calculating Weeks of Pregnancy

WISH will automatically calculate the weeks of pregnancy when you enter either the woman's EDD (expected delivery date) or first day of LMP (last menstrual period). We start counting weeks of pregnancy from the date her last menstrual period began. If you enter the LMP date, WISH will calculate her EDD.

Your local WIC agency may have gestational wheels for you to use; these vary in design, so ask for assistance on how to use them in your local agency.

### Example:

Let's calculate in WISH the week of Jane August's pregnancy for plotting her current weight.

Jane states her baby is due March 16. Today is December 12. Let's calculate in WISH how many weeks pregnant she is. Jane is 26 weeks pregnant.

First, on the pregnancy panel, you enter the EDD, LMP, pre-pregnancy weight, and save your information. Then on the Anthropometrics panel, enter current weight and height (first entry) and then save. WISH will plot the correct pregnancy weight gain grid for you. WISH will continue to plot her weight gain / loss throughout her pregnancy as you enter more weight measurements.

To plot the pregnancy weight gain or loss on a paper Prenatal Weight Gain Chart, follow these steps:

1. Select the appropriate weight gain chart based on the women's pre-pregnancy weight status and age.
2. Complete the information in the box at the top of the graph.
3. Find the week of pregnancy that the woman was weighed on the bottom horizontal line of the graph.
4. Place a dot on the grid where the line for the number of pounds gained or lost crosses the line for the week of gestation the weight was obtained.

**Note:** Medical care providers often change women's EDD later in pregnancy. Check to make sure the EDD is correct in WISH each time you enter a weight. If it has changed, change the date on the pregnancy panel in WISH and WISH will replot the weight gain grid.

### When Pre-pregnancy Weight is Unknown

If the woman does not know her pre-pregnancy weight, follow these steps at the first WIC visit:

1. Determine the woman's height and weight. From this information and your observation, estimate which prenatal weight gain grid to use. If you are not sure, use the weight gain grid for normal weight women.
2. Determine the week of gestation the woman was weighed.

3. Locate the number of weeks gestation on the bottom horizontal line of the grid. Follow that line up to the lower line of the weight gain range estimated to be appropriate for the woman and place a dot on the grid at that point.
4. From the dot, follow the line to find the number of pounds represented by the dot. Subtract this number from the current weight to determine estimated pre-pregnancy weight.

**Example:**

Veronica Brown does not know her pre-pregnancy weight. You will need to estimate it.

Veronica is 62 inches tall and weighed 150 pounds when 20 weeks pregnant. Veronica probably was overweight before she became pregnant, so you select the grid for overweight women. For overweight women, four (4) pounds is the lower target weight gain at 20 weeks.  $150 - 4 = 146$ .

You estimate her pre-pregnancy weight to be 146 pounds.

WISH will not plot a prenatal weight gain without a pre-pregnancy weight.

## Interpreting Anthropometric Measurements for Pregnant Women

### What Can Prenatal Weight Gain Grids Tell Us?

Weight plotted will tell us how a woman's weight has changed since she became pregnant. Some women will not be sure about their pre-pregnancy weight. If the pre-pregnancy weight is inaccurate, then we cannot accurately assess weight gained the first time a pregnancy weight is plotted. However, we will have a starting point to accurately assess future measurements during the pregnancy.

Several measurements plotted at different weeks of pregnancy give more reliable information to help determine if the woman is gaining a healthy amount of weight than a single measurement.

The end of this manual has sample pregnancy weight gain grids for underweight, normal weight, and overweight women.

### Prenatal Weight Gain

Both the pre-pregnancy weight and the weight gained during pregnancy affect the fetal growth and the infant's birth weight. Women who are underweight before pregnancy tend to have smaller babies than heavier women, even when both gain the same amount of weight during pregnancy.

Weight gain goals for underweight women are higher than those for normal weight or overweight women. Overweight pregnant women do not need to gain as much weight to deliver a normal weight infant as women who weigh less.

The table below lists the recommended ranges for weight gain based on pre-pregnancy weight for singleton pregnancies (a woman having one baby, not multiples). These guidelines are presented as ranges to help prevent either inadequate or excessive weight gain.

**Recommended Weight Gain Based on Pre-pregnancy BMI**

Pre-Pregnancy Weight Status	Body Mass Index	Recommended Weight Gain (lbs)
	<18.5	28-40
	18.5-24.9	25-35
	25.0-29.9	15-25
	≥ 30.0	11-20



## How Fast Should Pregnant Women Gain Weight?

The rate of weight gain is also important. To reach the recommended weight gain ranges listed in the table above, an average rate of weight gain can be given for the different trimesters of pregnancy. The usual weight gain during the first trimester is two to five (2-5) pounds. Weight gain for the 2<sup>nd</sup> and 3<sup>rd</sup> trimesters is listed in the table below.

### Weekly Rate of Weight Gain During the 2<sup>nd</sup> and 3<sup>rd</sup> Trimesters

---

<b>Pre gravid Weight Status</b>	<b>Recommended Gain</b>
BMI < 18.5	Slightly more than 1 pound / week
BMI 18.5-24.9	~1 pound / week
BMI 25.0-29.9	3/4 pound / week
BMI > 30	1/2 pound/ week

Remember that the suggested rate of weight gain is the average gain for each week. Very few pregnant women gain weight at the same rate each week.

Other factors to consider in setting weight gain goals for each pregnant client are:

- The quality of the woman's diet
- Her health history
- Her present health
- Her lifestyle
- There are 3500 calories in a pound

Women pregnant with twins should gain more weight than the recommended range.